



Colt CPV
Car Park Ventilation Systems



Traditional CPV Systems

COLT AND SMOKE CONTROL

Colt designed and installed the first modern smoke control system in 1956 at Vauxhall Motors Luton Plant.

Since then Colt has been involved in many fire research programmes such as The Portsmouth Fire Tests and Ghent, and have been heavily involved in writing many design documents including Fire Technical Papers Nos.7 and 10, BR 186, BR 258, the SVA Guide and BS 7346.

Colt has pioneered the development of smoke control across the world.

COLT AND CAR PARK VENTILATION

This brochure explains the various methods of ventilating a car park, from the traditional method of distributed ductwork to the extract fans to the latest designs utilising impulse systems.

This brochure also describes a new approach taken by Colt. Colt have supplemented the impulse system, with a new induction system using low profile, high airflow fans. These create greater momentum and more effective air movement, thus significantly reducing the number of fans required.

Colt can offer:

Impulse using the Colt Jetstream CPV (car park ventilation) system

and

Induction using the Colt Cyclone CPV (car park ventilation) system

REGULATIONS

Guidelines for CPV systems can be found in:

Approved Document B - Fire Safety

Approved Document F - Ventilation

BS 5588 Series

APEA Code of Practice

SVA guidance

BR 368

“A new tool is needed for the ventilation of car parks”

TRADITIONAL CPV

Approved Document B - Fire Safety and Approved Document F - Ventilation cover the recommended methods of complying with Building Regulations. They describe three traditional methods of ventilation.

These systems are not intended to assist means of escape in case of a fire, but to assist fire fighters by providing smoke clearance.

1. Open Sided Car Parks

These are completely above ground level with permanent wall openings on each level, which are equal to 5% of the plan area, arranged to provide cross ventilation. These openings are considered to provide sufficient ventilation for clearance of both smoke and vehicle exhaust fumes.

2. Naturally Ventilated Car Parks

These have permanent wall openings on each level, which are equal to 2.5% of the plan area, arranged to provide cross flow ventilation. This is sufficient ventilation for smoke clearance, but in addition mechanical extract providing three air changes per hour is needed to remove exhaust fumes. As an alternative to the wall openings, smoke ventilators can be provided in the ceiling to provide the equivalent of 2.5% of the car park area.

3. Mechanically Ventilated Car Parks

Where natural ventilation is not possible, a mechanical extract system can be used. This needs to achieve six air changes per hour for exhaust fume extract and ten air changes per hour for smoke clearance. This system is designed to work in two parts, each one capable of achieving 50% of the required extract rate. Each part has its own independent power supply to operate in the event of a mains power failure.

Extract points are designed to remove 50% at high level and the remainder at low level. The fans are rated to run at 300 degrees centigrade for a minimum of sixty minutes and the ductwork must have a melting point of not less than 800 degrees centigrade. The ductwork distribution must be planned to the satisfaction of the Local Statutory Authority to ensure efficient extract from all parts of the car park.

The Modern Approach

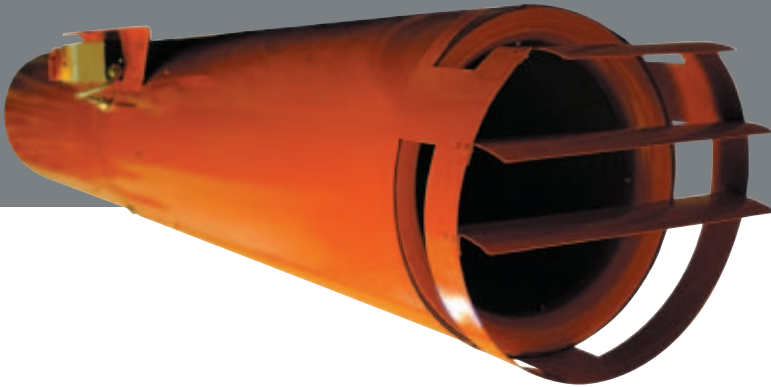

WHAT IS IMPULSE VENTILATION?

This system uses the principle of adding momentum to the air to thrust it towards an extract point and to ensure that there are no dead spots for fumes and smoke to stagnate and collect.

A series of small fans, mounted under the ceiling, direct airflow from the air inlet opening to the exhaust fans, effectively clearing smoke and fumes in the process. The number and location of fans are carefully chosen to match the system design requirements.

IMPULSE VENTILATION

Impulse ventilation in car parks has been developed from well proven tunnel ventilation methods. Although relatively new, impulse ventilation systems are becoming increasingly popular.

The major benefit of the system is that it removes the need for distribution ductwork in the car park. This provides more space for parking bays. The environment is safer, with improved lighting and leads to better security from CCTV systems. The installation of the equipment is much easier and significantly quicker.

ADVANTAGES

- No ducting required**
- Increased headroom**
- Increased number of parking bays**
- Safer, lighter environment**
- Improved security for CCTV**
- Easier and quicker installation**
- Energy efficient**

The principles of car park ventilation first mirrored procedures used for tunnel ventilation. In the event of a fire, smoke would be 'pushed' and 'pulled' to the exit. Vehicles in front of the fire would continue through to the exit, whilst vehicles behind the fire would, of course, have to stop. Although trapped, these vehicles should be safe from the smoke

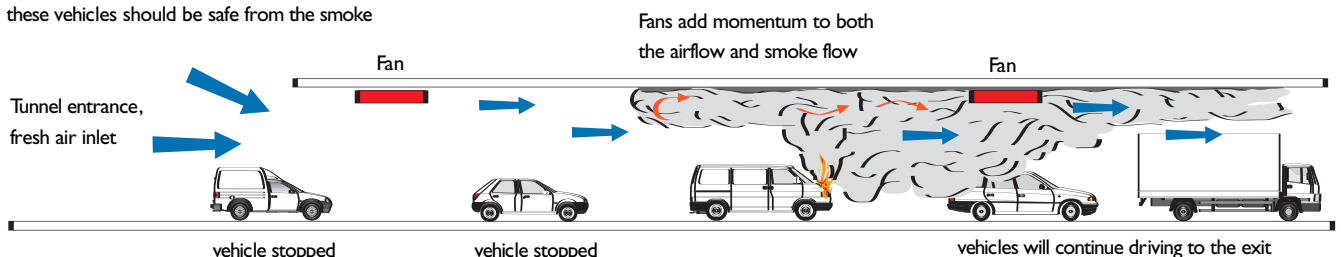

“Impulse ventilation systems are the most significant new weapon made available to the industry in the last 25 years”

Quote from The British Parking Association

IMPULSE DESIGN APPROACH

There are two design approaches that can be adopted:

Smoke Clearance

For a fully mechanically ventilated car park, the extract system should be sized to provide six and ten air changes per hour as recommended in the Approved Documents B and F. The impulse fans are then located over the roadways in a layout engineered to ensure there are no areas where it would be possible for fumes to build up, due to lack of air movement. This method satisfies the requirements of both Approved Documents.

Smoke Control

Impulse ventilation can provide much improved conditions over a conventional or impulse smoke clearance system. Utilising the principles from tunnel ventilation, impulse ventilation can be used to maintain parts of a car park clear of smoke, allowing better conditions or allowing occupants to escape and for the Fire and Rescue Service to approach and fight the fire.

Using an addressable FDS to pinpoint the location of the fire, the control system can selectively operate the desired fans to control the direction of the smoke flow, delivering it directly to the extract fans and limiting its spread.

Upstream areas are thereby kept substantially smoke free.

This system requires more complex design and sophisticated controls and usually involves an increase in the design air flow rates. It conforms to but is not required under the guidelines stated in the Approved Document. It is most commonly used as part of a fire engineered solution.

There are currently no standards or published methods for design of impulse ventilation systems, therefore the design is normally proven by use of CFD analysis.

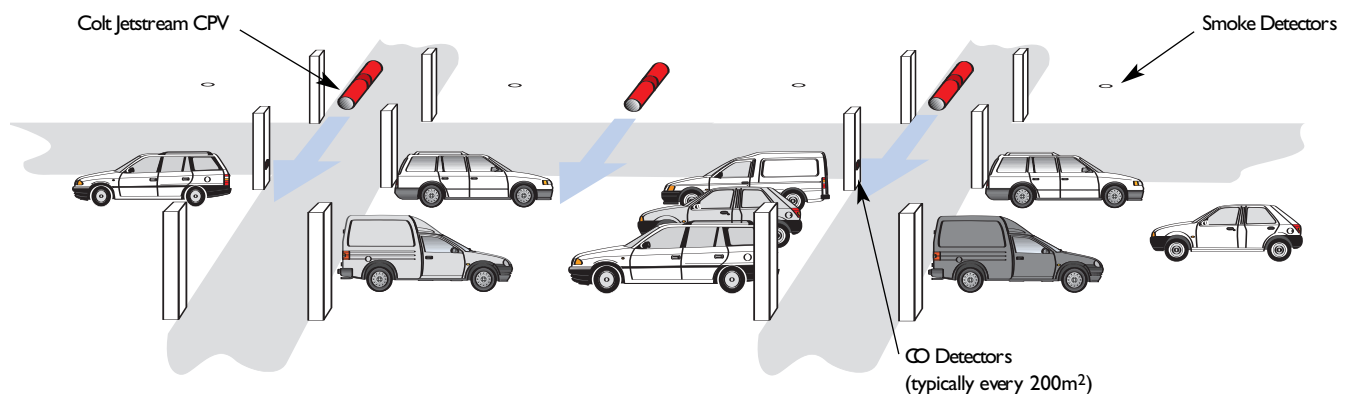

Fan positioning needs to take into account roof geometry (particularly deep downstand roof beams) and risk of airflow blockage by tall vehicles

The introduction of CO detectors allows use of a more sophisticated control system to match the ventilation rate to the car park usage, reducing running costs and noise levels

The Next Step



WHAT'S NEXT?

Colt have developed a new system to overcome the problems of low car park headroom and airflow turbulence by using laminar airflow fans. These fans create greater airflow momentum, with better directional controls, and are contained in a slimline low profile unit. This results in a more efficient and powerful system, reducing the number of fans required in comparison with an impulse system.

Backed by extensive CFD analysis, Colt can offer the complete CPV package including extract and induction fans, smoke and CO detectors, control, extract ductwork and wiring.

THE COLT CYCLONE

A typical impulse fan will move air or smoke at 20m/s. By comparison, the Cyclone will move a greater extract rate of air or smoke at 25m/s.

This equates to the Cyclone fan adding 2.5 times as much momentum to the air therefore fewer are needed.



Colt Cyclone CPV fan utilises a backward curved centrifugal fan to provide higher performance than other car park ventilation fans

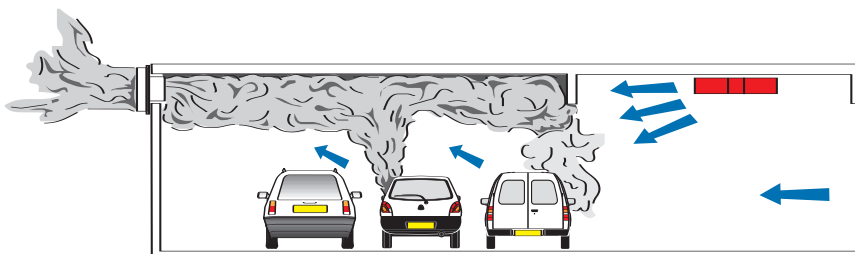

Figure 1

Air turbulence created by the downstands when using a typical impulse fan

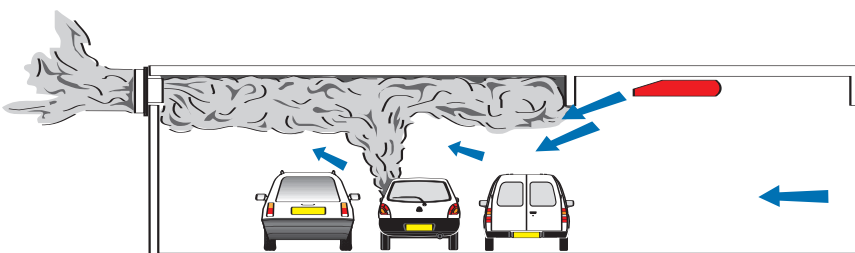
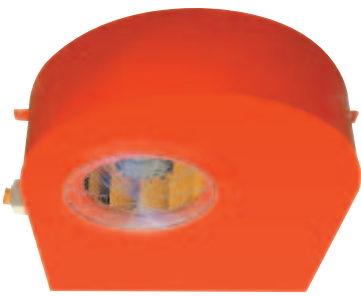

Figure 2

Air turbulence is dramatically reduced when using a Colt Cyclone CPV fan

“Colt have managed to push the boundaries out further”

CYCLONE DIMENSIONS



Colt Cyclone CPV from front and rear of fan

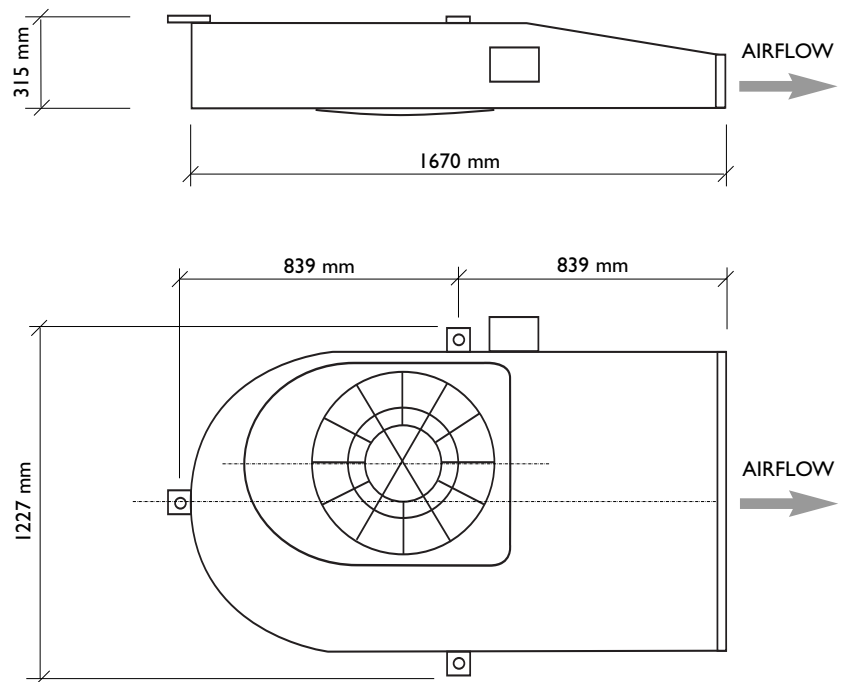

TECHNICAL INFORMATION

The Cyclone laminar airflow fan incorporates a backward curve centrifugal impeller with a high temperature external rotor motor rated at 300°C for one hour.

The streamlined casing is manufactured from 3mm 2-pack epoxy coated steel with directional outlet diffuser.

Access to the motor and impeller is achieved by simply removing the aerodynamic inlet venturi and then removing the access cover plate.

Unit height	315 mm
Unit length	1670 mm
Unit width	1150 mm
Motor Speed	1385 rpm
Motor kW	2.6 kW
FLC	6.3 Amps
SC	35 Amps
Protection	IP54
Supply	415V 3 Phase 50 Hz

The Colt Cyclone is tested to conform to BS 7346 Part 2.

Controls

CONTROL SYSTEM

Control systems can be simple or sophisticated as required by the project specifications. Simple systems have a low initial cost and are easy to commission and maintain, but there may be a significant energy penalty in use, depending upon the car park usage pattern.

General Ventilation

The simplest option is to run the system at a constant speed, providing a ventilation rate of 6 ACH throughout the car park.

To reduce energy costs a CO detection system may be used to allow the system to run at a reduced ventilation rate in periods when vehicle movements are low. Using a single output detector, two stage control can be provided, typically switching at 30ppm CO. Using variable output detectors, the system can modulate using inverter controls to match the ventilation rate to the car park usage.

Smoke Ventilation

For a smoke clearance system fire detection is required to indicate which level of the car park contains the fire. Upon detection all CPV fans on that level operate at high speed, all other CPV fans are switched off and the extract fans are switched to full speed, extracting only from the fire level. In some cases, a short delay is required by the Authorities during the switching process to allow occupants to escape from the car park.

For a smoke control system, detection is required to pinpoint the fire location to allow correct selection of fan operation to maintain the required clear zones. No delay in switching is normally required for this system.

TYPICAL CONTROL SCHEMATIC

Shown below is a typical control system for a two level car park with CO control, mechanical exhaust and mechanical inlet

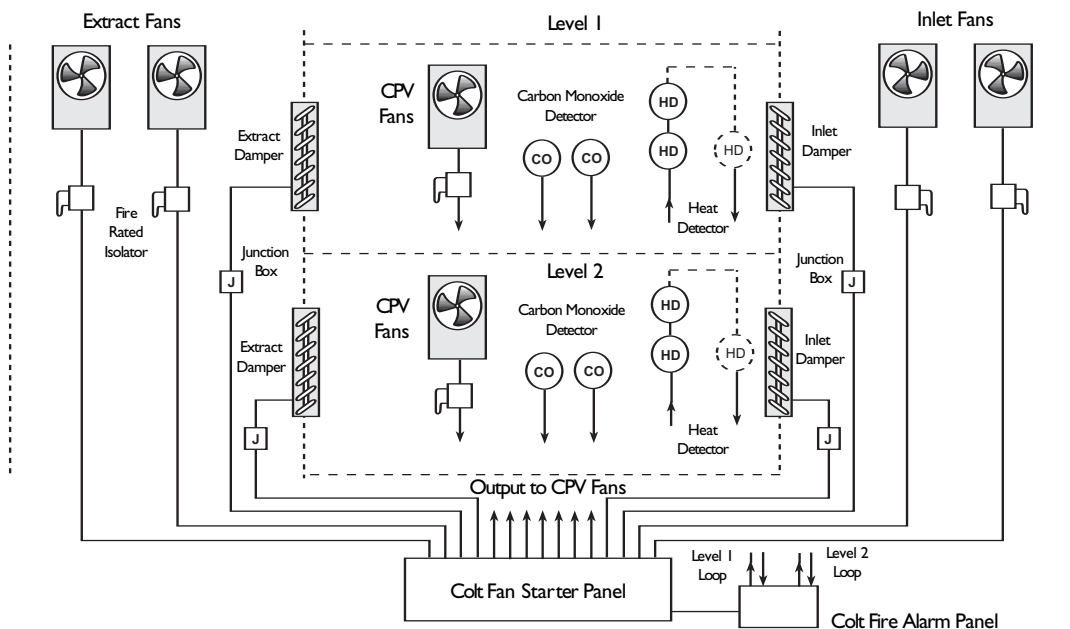

TYPICAL SYSTEM DESIGN SCHEMATIC

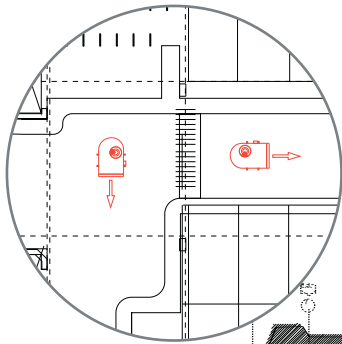

Positioning the CPV fans over the road ways will provide two functions, fume extraction and smoke clearance

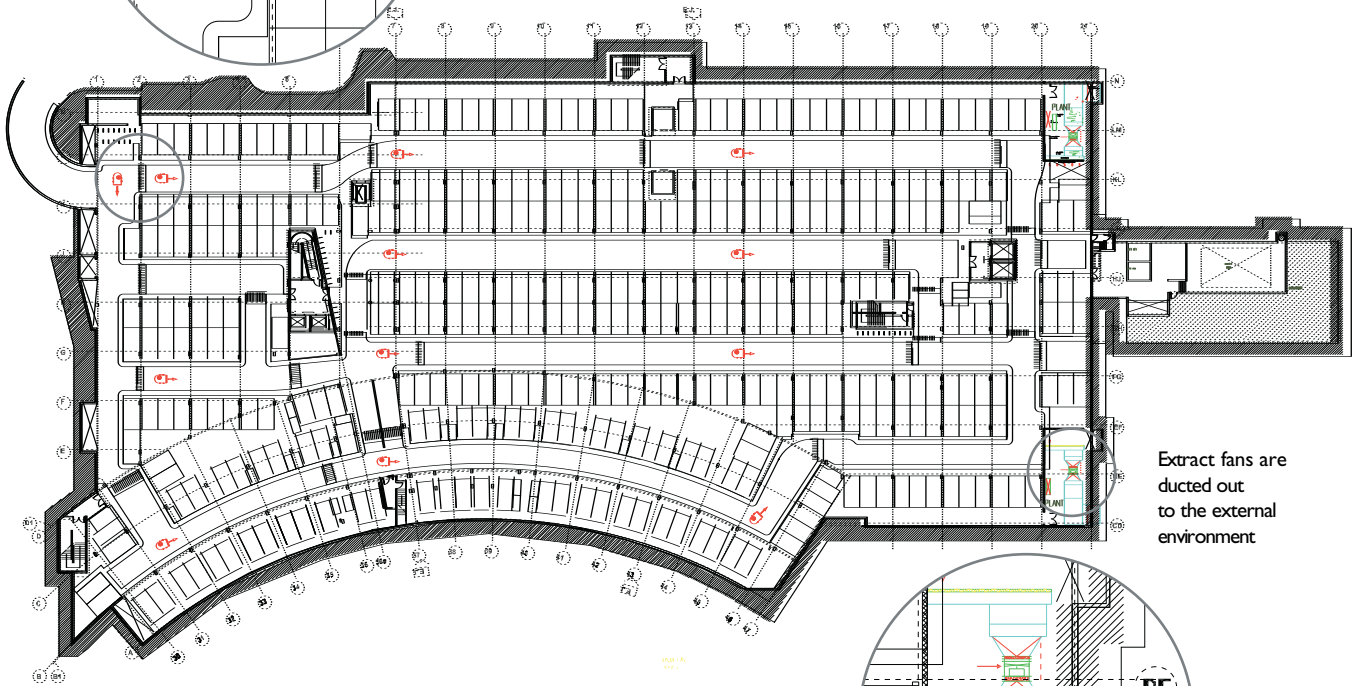

Extract fans are ducted out to the external environment

CPV fans must be able to direct fumes and smoke towards the extract fans

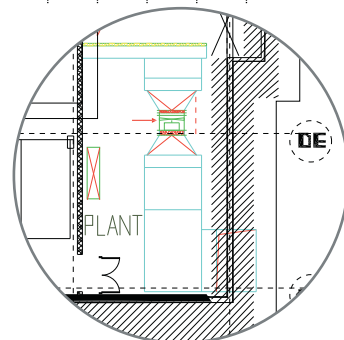

WHY CFD?

CFD is now a common tool for solving complex fluid flow problems. CFD provides detailed quantitative predictions of fluid flows. The level of detail allows better design decisions to be made and provides greater confidence in the results.

WHY CFD IN CAR PARKS?

CFD is the ideal tool for confirming design. It is used to demonstrate that sufficient air movement is provided throughout the car park and, for smoke control systems, the extent of the smoke zone.

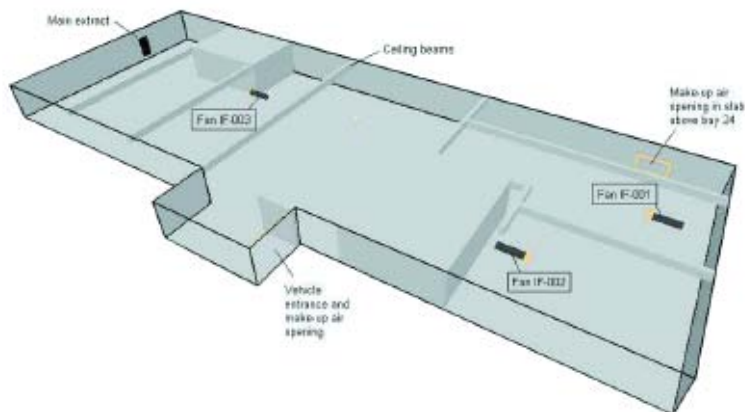

Typical CFD plan of car park

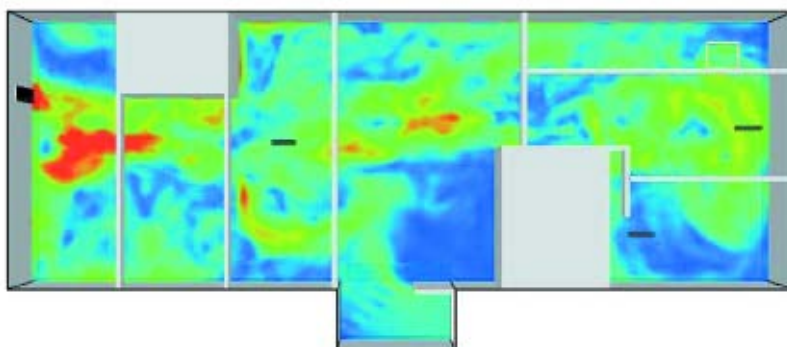

CFD showing air speed contours at low level for smoke control

The above CFD examples are actual outputs used in the design of the Fairlawns Project, Lytham St Annes

“The benefits of a CPV system can be reaped by the car park owners, users, designers and the Fire Service”

Quote from The British Parking Association

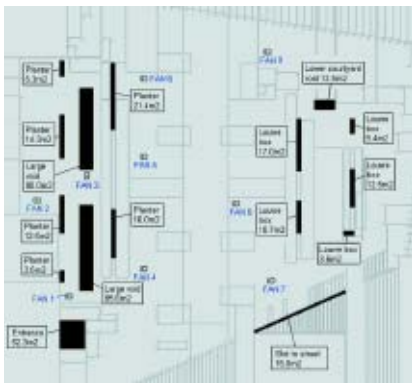

CFD plan of car park showing Colt Cyclone fan locations, openings and areas

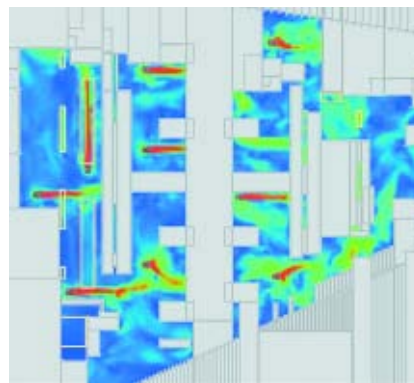

Air speed contours at high level, day-to-day ventilation

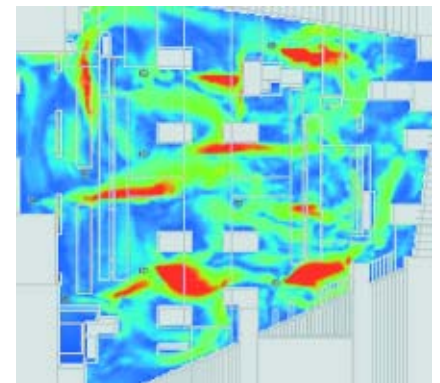

Air speed contours at low level, day-to-day ventilation

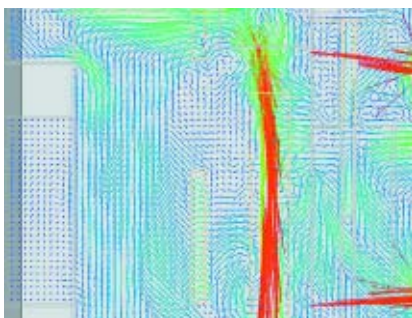

Velocity vectors at high level (upper left hand side of plan)

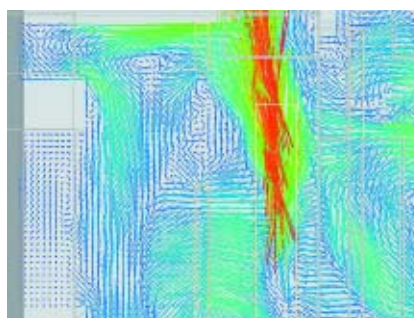

Velocity vectors at low level (upper left hand side of plan)

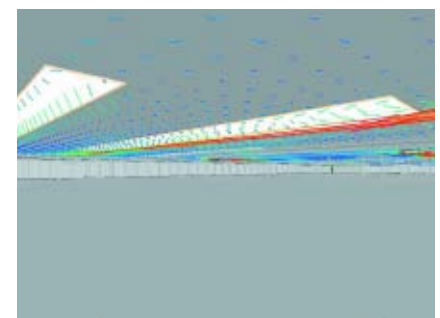

Inflow through planter opening and mixed flow through large void

The above CFD examples are actual outputs used in the design of the Southside Project, Birmingham, based on the Colt Cyclone CPV system



Alarmatic y el Medio Ambiente, unidos por la Eficiencia Energética.

Los Olmos 2950, Macul, Santiago
 Tel: (56 2) 595 3000 – 800 710 710
 Calama: Latorre 1456, Tel: 55 364 041 - CHILE
 e-mail: alarmatic@alarmatic.cl – www.alarmatic.cl

THE COLT PACKAGE

Colt can offer the complete package, including the design, supply and installation of:

CPV fans

CO and Smoke detectors

Strobe lighting and sounders (if required)

Wiring

Ductwork (extract)

Extract ventilators

Control system

Fan starters

CFD report

Commissioning

Service and maintenance

Also, for traditional systems Colt can offer louvres for natural cross-flow ventilation.

COLT SERVICE

Part of the Colt Group of companies, Colt Service offers a comprehensive range of maintenance packages incorporating the maintenance and repair of all building services equipment including non Colt products.

Colt Service provide a 24 hour, 365 day emergency cover as standard.

MAINTENANCE

Maintenance of a smoke control system is essential. Regular maintenance protects your investment and brings peace of mind that the system will operate effectively in an emergency.

The British Standard, BS 7346 recommends that smoke control systems should be serviced at least once a year and tested weekly.



A Member of the British Parking Association



Architectural Solutions

Climate Control

Smoke Control

Service and Maintenance

Colt International Limited

New Lane Havant

Hampshire PO9 2LY

Tel +44(0)23 9245 1111

Fax +44(0)23 9245 4220

info@coltgroup.com

www.coltgroup.com